

IMPORTANT

This document is intended for use by authorized Nokia service centers only. Please use the document together with other documents such as the Service Manual and Service Bulletins.

Version information

While every effort has been made to ensure that the document is accurate, some errors may exist. Please always check for the latest published version for this document.

If you find any errors in the document please send email to:
service.manuals@nokia.com

Version history

- 1.0 First approved version
- 2.0 Resistor codes in SIM lines corrected

This material, including documentation and any related computer programs is protected by copyright, controlled by Nokia. All rights are reserved. Copying, including reproducing, modifying, storing, adapting or translating any or all of this material requires the prior written consent of Nokia. This material also contains company confidential information, which may not be disclosed to others without the prior written consent of Nokia.

Service Schematics

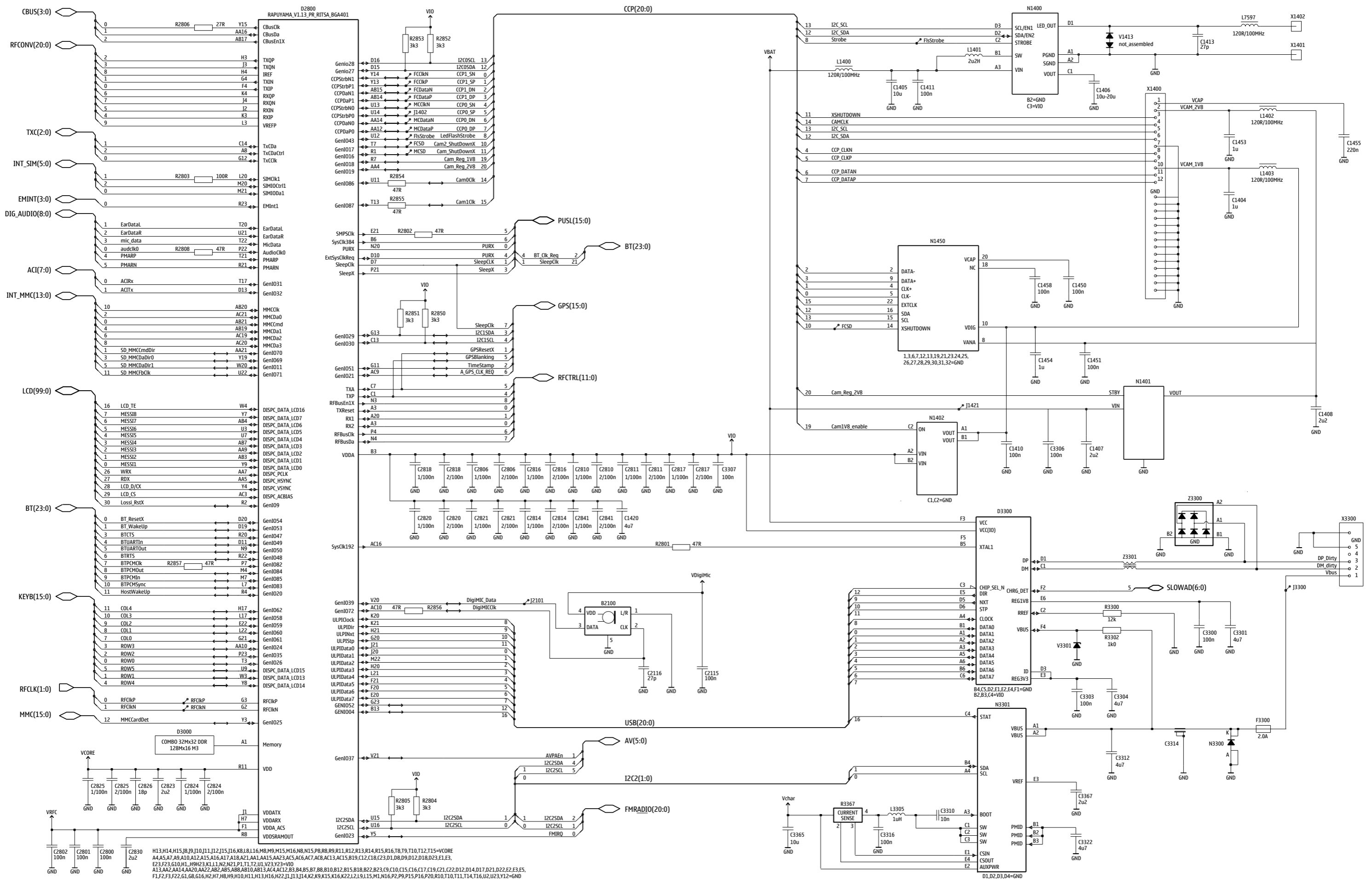
NOKIA C5-00

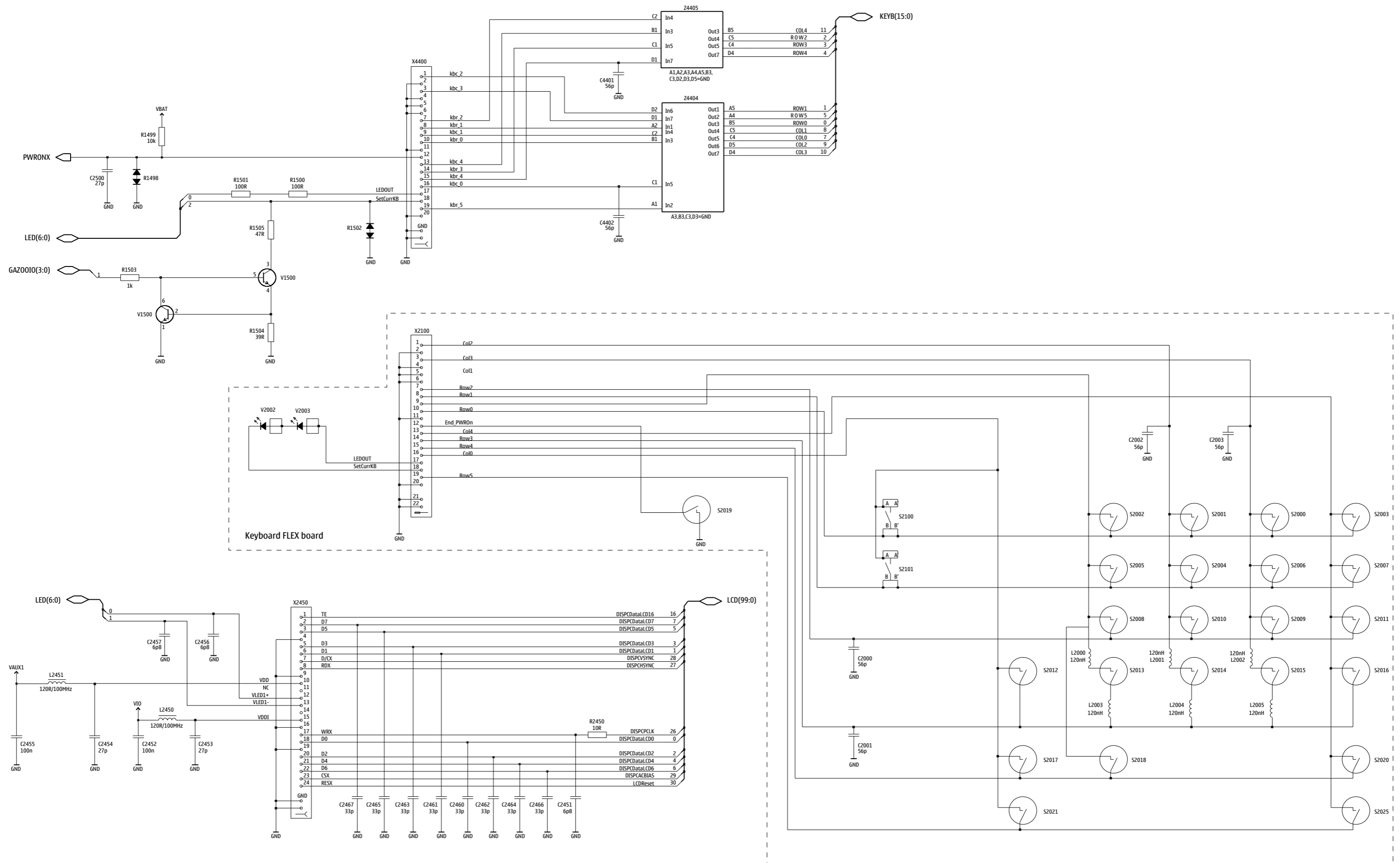
RM-645

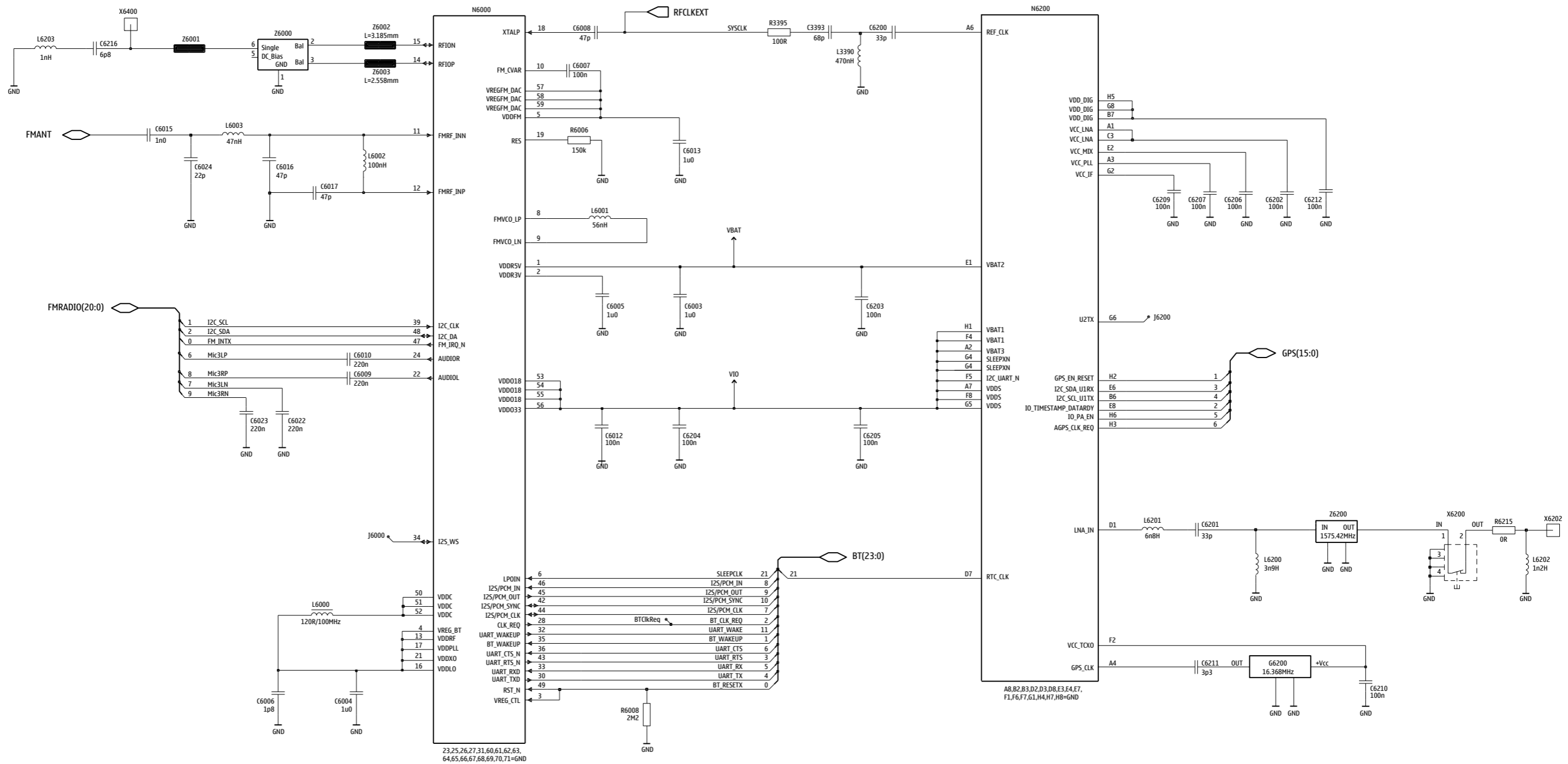


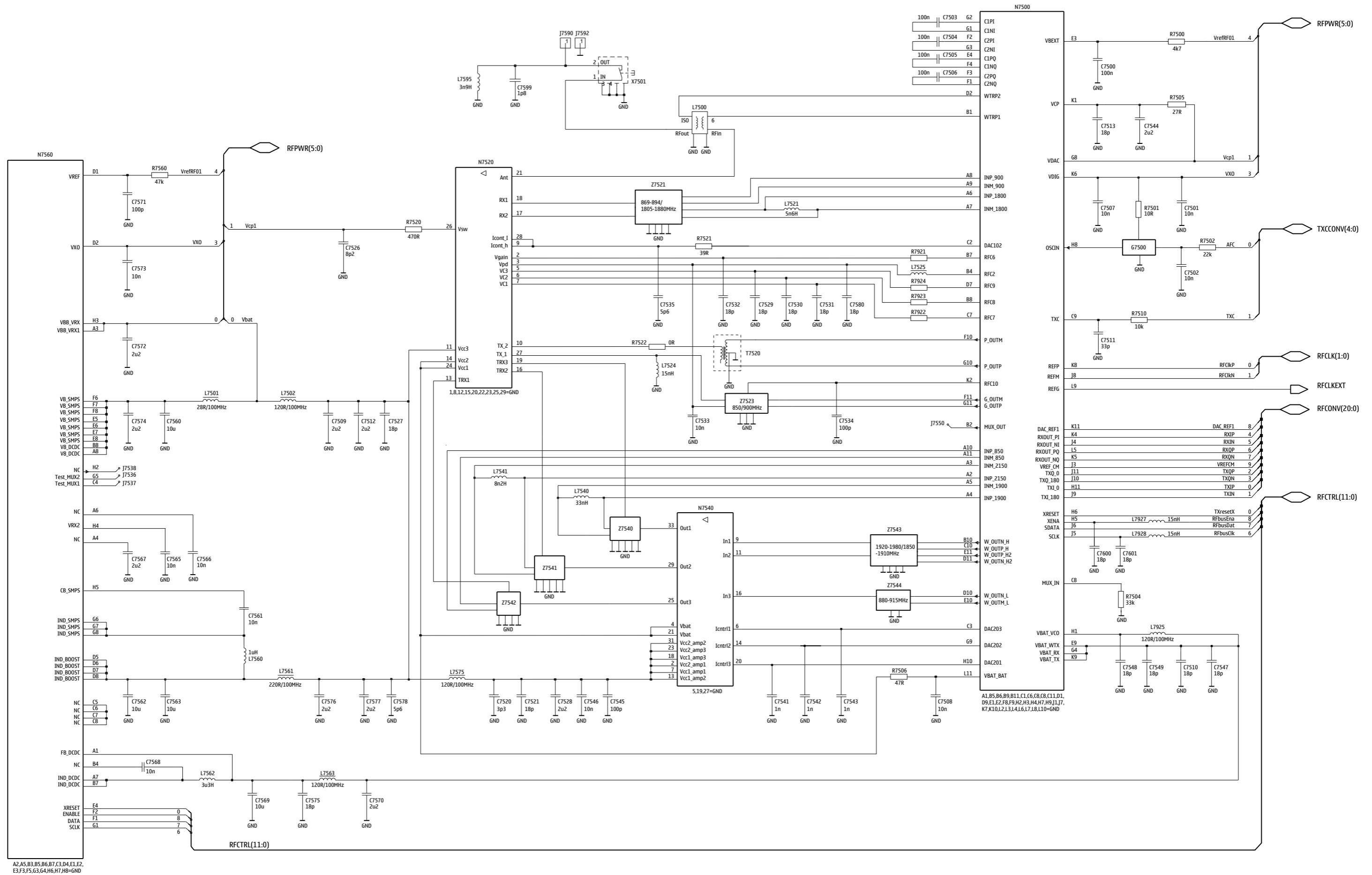
Table of Contents

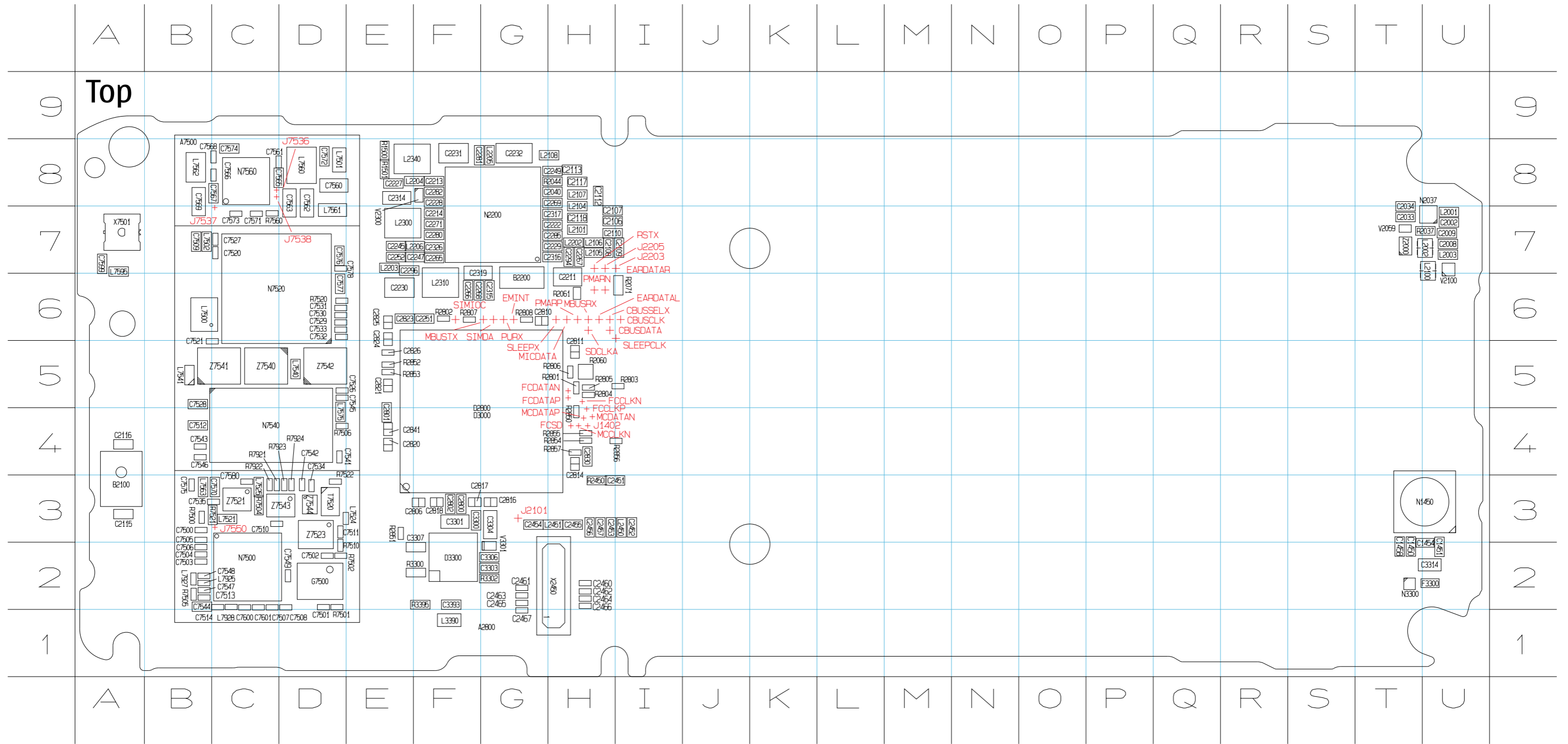
Front page	1
RAPS, HS USB, Memory, Camera	2
GAZOO, Audio, Battery, MMC, SIM	3
UI, Keyboard Flex	4
BTH FM, GPS	5
RF Part	6
Component Finder Top	7
Component Finder Bottom	8
Component Finder Keyboard Flex	9



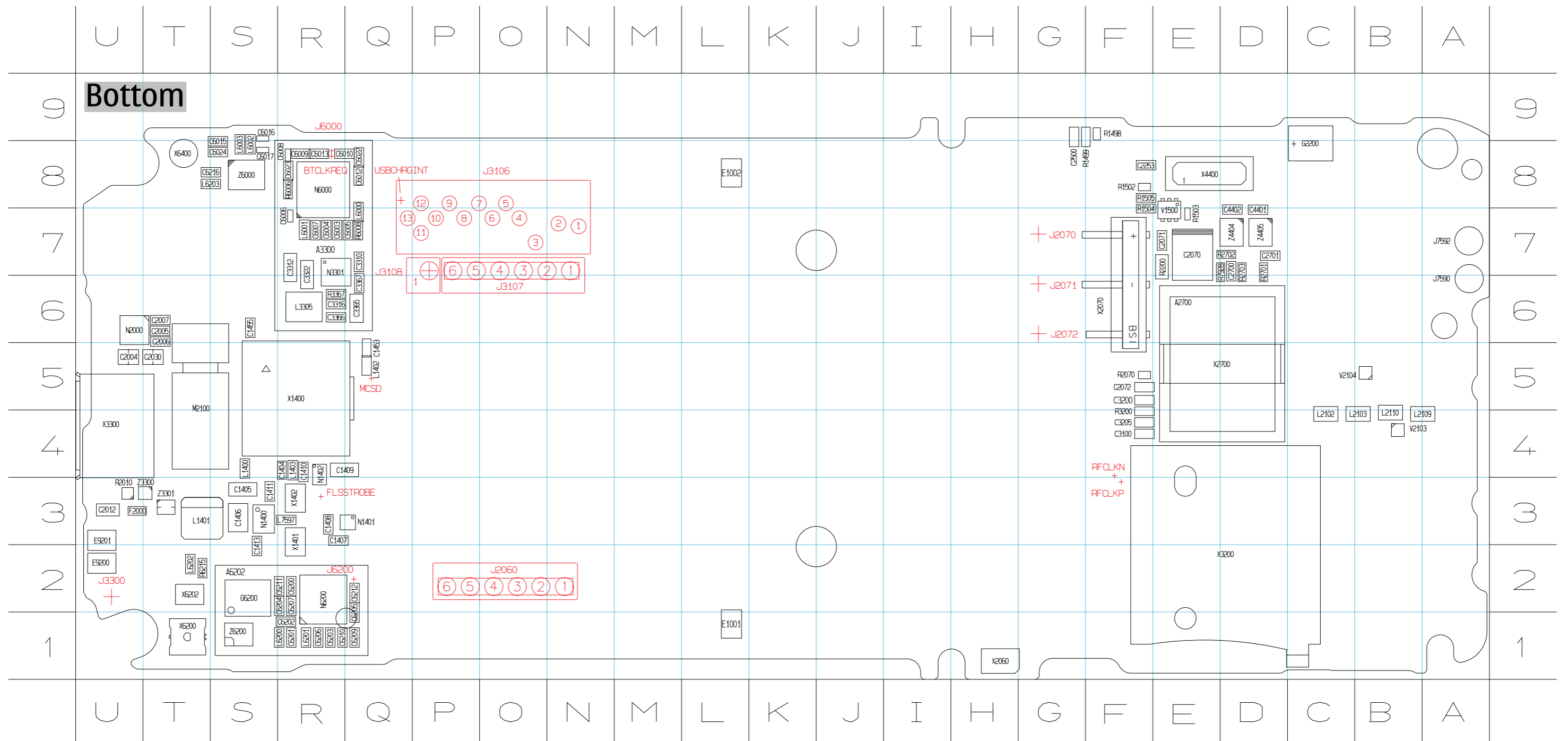








A	C2008	U7	C2115	A3	C2231	F8	C2271	F7	C2326	F7	C2464	H2	C2817	F3	C3303	G2	C7506	B2	C7527	C7	C7544	B2	C7567	C8	C7580	C3	L	L2203	E7	L7502	B7	L7925	B2	R	R2804	H5	R2857	H4	R7521	C3	V2300	F8	Z7543	D3			
A2800	G5	C2009	U7	C2116	A4	C2232	G8	C2280	F7	C2451	H3	C2465	G2	C2818	F3	C3304	G3	C7507	C2	C7528	B5	C7545	D5	C7568	C8	C7599	A7	L2001	U7	L2204	F8	L7521	C3	L7927	B2	R1500	E8	R2805	H5	R3300	F2	R7522	D3	V3301	G2	Z7544	D3
A7500	C5	C2033	T7	C2117	H8	C2245	E7	C2281	F8	C2452	I3	C2466	H2	C2820	E4	C3306	G2	C7508	D2	C7529	D6	C7546	B4	C7569	B8	C7600	C2	L2002	U7	L2205	G8	L7524	D3	L7928	C2	R1501	E8	R2806	H5	R3302	G2	R7560	C7	X			
B	C2034	T7	C2118	H7	C2247	F7	C2282	F8	C2453	H3	C2467	G1	C2821	E5	C3307	F2	C7509	B7	C7530	D6	C7547	B2	C7570	C3	C7601	C2	L2003	U7	L2206	F7	L7525	C3	N	R2037	U7	R2807	F6	R3395	F2	R7921	C3	X2450	H2				
B2100	A3	C2040	H8	C2211	H6	C2249	H8	C2285	H7	C2454	G3	C2800	F3	C2823	E6	C3314	U2	C7510	C3	C7531	D6	C7548	B2	C7571	C7	D	L2100	U7	L2300	E7	L7540	D5	N1450	U3	R2044	H8	R2808	G6	R7500	B3	R7922	C3	X7501	A7			
B2200	G6	C2106	H7	C2213	F8	C2251	F6	C2294	H7	C2455	H3	C2801	E4	C2824	E6	C3393	F2	C7511	D3	C7532	D6	C7549	D2	C7572	D8	D2800	G4	L2101	H7	L2310	F6	L7541	B5	N2037	U7	R2060	H5	R2850	H4	R7501	D2	R7923	D3	Z			
C	C2107	H7	C2214	F7	C2252	E7	C2296	E7	C2456	H3	C2802	F3	C2825	E6	C7500	B3	C7512	B4	C7533	D6	C7560	D8	C7573	C7	D3000	G4	L2104	H7	L2340	E8	L7560	D8	N2200	G7	R2061	H6	R2851	E3	R7502	D2	R7924	D3	Z2000	T7			
C1450	T2	C2108	H7	C2222	H7	C2265	F7	C2314	E8	C2457	H3	C2806	F3	C2826	E5	C7501	D2	C7513	B2	C7534	D3	C7561	C8	C7574	C8	D3300	F2	L2105	H7	L2450	I3	L7561	D7	N3300	T2	R2071	I6	R2852	E5	R7504	C3	T	Z7521	C3			
C1451	U2	C2109	I7	C2227	E8	C2266	F6	C2315	G6	C2460	H2	C2810	G6	C2830	H4	C7502	D2	C7514	C2	C7535	C3	C7562	D8	C7575	B3	F	L2106	H7	L2451	H3	L7562	B8	N7500	C2	R2450	H3	R2853	E5	R7505	B2	T7520	D3	Z7523	D3			
C1454	U2	C2110	H7	C2228	F8	C2267	H7	C2316	H7	C2461	G2	C2811	H5	C2841	E4	C7503	B2	C7520	C7	C7541	D4	C7563	D8	C7576	D7	F3300	U2	L2107	H8	L3390	F1	L7563	B3	N7520	C6	R2801	H5	R2854	H4	R7506	D4	V	Z7540	C5			
C1458	T2	C2112	H8	C2229	H7	C2268	F6	C2317	H7	C2462	H2	C2814	H4	C3300	F3	C7504	B2	C7521	C5	C7542	D3	C7565	C8	C7577	D6	G	L2108	H8	L7500	B6	L7575	D4	N7540	C4	R2802	F6	R2855	H4	R7510	D2	V2059	T7	Z7541	C5			
C2002	U7	C2113	H8	C2230	E6	C2269	H8	C2319	F7	C2463	G2	C2816	G3	C3301	F3	C7505	B3	C7526	D5	C7543	B4	C7566	C8	C7578	D7	G7500	D2	L2202	H7	L7501	D8	L7595	A7	N7560	C8	R2803	I5	R2856	I4	R7520	D6	V2100	U7	Z7542	D5		



A	C1413	S2	C2500	G9	C4401	D7	C6016	S9	C6209	Q1	G2200	C8	L2110	B4	N	R1504	F7	R7928	D7	X3300	U4		
A2700	D5	C1453	Q5	C2700	D7	C4402	D7	C6017	S8	C6210	R1	G6200	S2	L3305	R6	N1400	S3	R1505	F8	V	X4400	E8	
A3300	R7	C1455	S6	C2701	D7	C6003	R7	C6022	Q8	C6211	R2	J	L6000	Q7	N1401	Q3	R2010	U3	V1500	E7	X6200	T1	
A6202	R2	C2004	U5	C3100	F4	C6004	R7	C6023	R8	C6212	Q2	J7590	A6	L6001	R7	N1402	R4	R2070	F5	V2103	B4	X6202	T2
C	C2005	T6	C3200	F5	C6005	Q7	C6024	S8	C6216	S8	J7592	A7	L6002	S8	N2000	U6	R2200	E7	V2104	B5	X6400	T8	
C1404	R4	C2006	T6	C3205	F4	C6006	R7	C6200	R2	E	L	L6003	S8	N3301	R7	R2701	D7	X	Z				
C1405	S3	C2007	T6	C3310	Q7	C6007	R7	C6201	R1	E1001	L1	L1400	S4	L6200	R1	N6000	R8	R2702	D7	X1400	R5	Z3300	T3
C1406	S3	C2012	U3	C3312	R7	C6008	R8	C6202	R1	E1002	L8	L1401	T3	L6201	R1	N6200	R2	R2703	D7	X1401	R3	Z3301	T3
C1407	R3	C2030	T5	C3316	R6	C6009	R8	C6203	R1	E9200	U2	L1402	Q5	L6202	T2	R	R3200	F4	X1402	R3	Z4404	D7	
C1408	R3	C2070	E7	C3322	R7	C6010	R8	C6204	R2	E9201	U3	L1403	R4	L6203	S8	R1498	F9	R3367	R6	X2060	H1	Z4405	D7
C1409	R4	C2071	E7	C3365	Q6	C6012	Q8	C6205	Q1	F	L2102	C4	L7597	R3	R1499	F9	R6006	R8	X2070	F6	Z6000	S8	
C1410	R4	C2072	F5	C3366	R6	C6013	R8	C6206	R1	F2000	U3	L2103	B4	M	R1502	F8	R6008	Q7	X2700	D5	Z6200	S1	
C1411	S3	C2253	F8	C3367	Q6	C6015	S8	C6207	R2	G	L2109	A4	M2100	T4	R1503	E7	R6215	T2	X3200	D2			

C	
C2000	E2
C2001	F2
C2002	G2
C2003	H2
L	
L2000	E2
L2001	H2
L2002	H2
L2003	F2
L2004	F2
L2005	H2
S	
S2100	K15
S2101	K13
V	
V2002	E9
V2003	H9
X	
X2100	A5

